

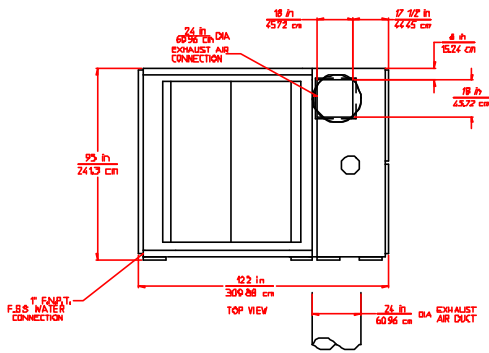

AD-464

MAXIMUM CAPACITY (DRY WEIGHT)		460 lb	208.65 kg
MINIMUM LOAD SIZE		250 lb	113.40 kg
TUMBLER DIAMETER		69-1/8"	175.59 cm
TUMBLER DEPTH		80-5/16"	203.99 cm
TUMBLER VOLUME		175 cu ft	4955.44 L
DOOR OPENING (WIDTH X HEIGHT)		53-1/4" x 49"	135.26 cm x 124.46 cm
DOOR SILL HEIGHT, LEVEL		45"	114.30 cm
DOOR SILL HEIGHT, REAR TILT		43-3/4"	111.13 cm
DOOR SILL HEIGHT, FRONT TILT		65-5/8"	166.70 cm
CABINET OPERATING DEPTH, LEVEL (1 DOOR/2 DOOR)		95" / 95"	241.30 cm / 241.30 cm
CABINET WIDTH		122"	309.88 cm
REAR TILT		15°	
FRONT TILT		15°	
WATER CONNECTION		1" F.N.P.T.	
Gas	CABINET REAR TILT HEIGHT	138-1/4"	351.16 cm
	CABINET OPERATING HEIGHT, LEVEL	121"	307.34 cm
	CABINET FULL TILT DEPTH	118"	299.72 cm
	APPROX. NET WEIGHT	10,270 lb	4,658.39 kg
	APPROX. SHIPPING WEIGHT	10,425 lb	4,728.70 kg
	VOLTAGE AVAILABLE	208-480v 3ø 3,4w 50/60 Hz	
	TUMBLER/DRIVE MOTOR	7-1/2 hp	5.59 kW
	BLOWER/FAN MOTOR	25 hp	18.64 kW
	BURNER BLOWER MOTOR	1-1/2 hp	1.12 kW
	BURNER TYPE	On / Off	
	HEAT INPUT	2,800,000 Btu/hr	705,588 kcal/hr
	INLET PIPE CONNECTION (NON-TILT/TILT)	2-1/2" F.N.P.T.	
	MAXIMUM GAS PRESSURE	12 in WC	29.89 mb
	AIRFLOW	13,000 cfm	368.12 cmm
	MAXIMUM EXHAUST BACK PRESSURE	1.25 in WC	3.11 mb
	EXHAUST DIAMATER	24"	60.96 cm
	COMPRESSED AIR PRESSURE	80 psi (± 10 psi)	5.52 bar (± 0.69 bar)
	COMPRESSED AIR VOLUME (1-WAY/2-WAY TILT)	15 cfh / 19 cfh	0.42 cmh / 0.54 cmh
COMPRESSED AIR CONNECTION (NON-TILT/TILT)	3/8" F.N.P.T.		
Steam	CABINET REAR TILT HEIGHT	138-1/4"	351.16 cm
	CABINET OPERATING HEIGHT, LEVEL	121"	307.34 cm
	CABINET FULL TILT DEPTH	118"	299.72 cm
	APPROX. NET WEIGHT	11,000 lb	4,989.52 kg
	APPROX. SHIPPING WEIGHT	11,162 lb	5,063 kg
	VOLTAGE AVAILABLE	208-480v 3ø 3,4w 50/60 Hz	
	TUMBLER/DRIVE MOTOR	7-1/2 hp	5.59 kW
	BLOWER/FAN MOTOR	25 hp	18.64 kW
	BOILER HORSEPOWER (NORMAL LOAD)	60 Bhp	
	SUPPLY CONNECTION	2-1/2" F.N.P.T.	
	RETURN CONNECTION (NON-TILT/TILT)	1-1/4" F.N.P.T.	
	STEAM CONSUMPTION	2,071 lb/hr	939.39 kg/hr
	AIRFLOW	13,000 cfm	368.12 cmm
	MAXIMUM EXHAUST BACK PRESSURE	1.25 in WC	3.11 mb
	EXHAUST DIAMETER	24"	60.96 cm
	COMPRESSED AIR PRESSURE	80 psi (± 10 psi)	5.52 bar (± 0.69 bar)
	COMPRESSED AIR VOLUME (1-WAY/2-WAY TILT)	16 cfh / 20 cfh	0.45 cmh / 0.57 cmh
	COMPRESSED AIR CONNECTION (NON-TILT/TILT)	3/8" F.N.P.T.	



ADG-464

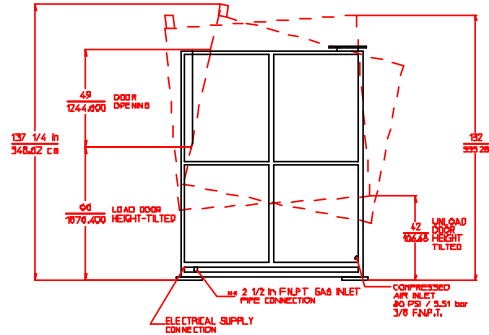
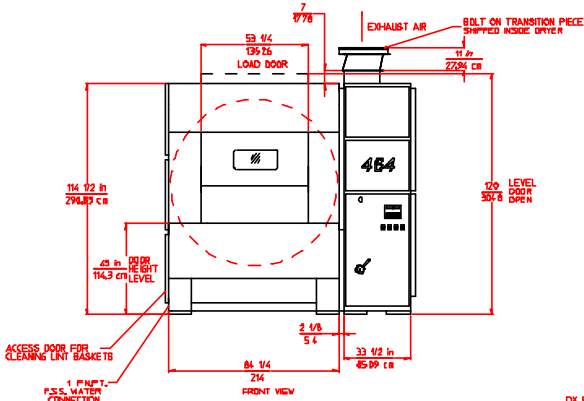

*DUCT WORK MUST BE A MINIMUM OF 3" DIAMETER 4606 mm DIA. DUCT WORK SIZE VARIES WITH INSTALLATION CONDITIONS.

** SIZE OF PIPING TO DRYER VARIES WITH INSTALLATION CONDITIONS. CONTACT FACTORY FOR ASSISTANCE.

DK 01/01/04

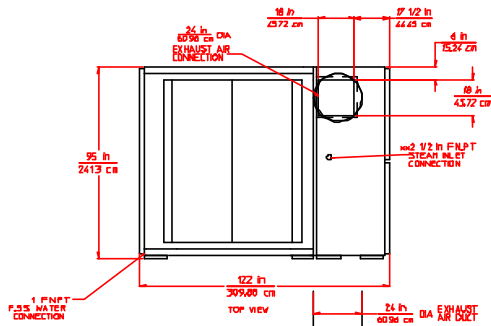

ADS-464

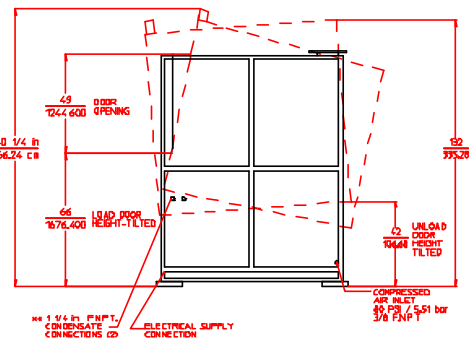
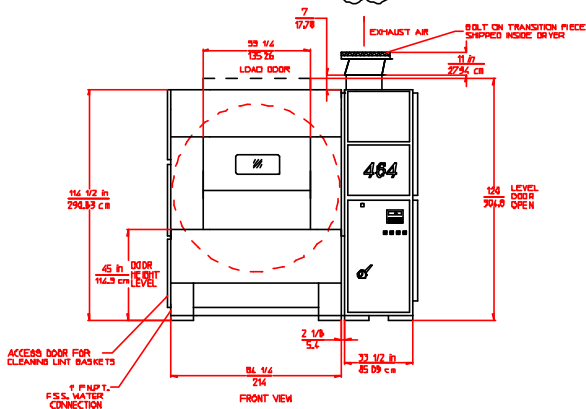

*DUCT WORK MUST BE A MINIMUM OF 3" DIAMETER 4606 mm DIA. DUCT WORK SIZE VARIES WITH INSTALLATION CONDITIONS.

** SIZE OF PIPING TO DRYER VARIES WITH INSTALLATION CONDITIONS. CONTACT FACTORY FOR ASSISTANCE.



88 Currant Road • Fall River, MA 02720
 Tel. 508-678-9000 • Fax 508-678-9447
 sales@amdry.com • www.amdry.com