



## AD-120HEPA

MAXIMUM CAPACITY (DRY WEIGHT)		120 lb	<b>54.43 kg</b>
TUMBLER DIAMETER		44-1/2"	<b>113.03 cm</b>
TUMBLER DEPTH		42-1/2"	<b>107.95 cm</b>
TUMBLER VOLUME		38.20 cu ft	<b>1,081.70 L</b>
TUMBLER/DRIVE MOTOR		3/4 hp	<b>0.56 kW</b>
BLOWER/FAN MOTOR		3 hp	<b>2.24 kW</b>
DOOR OPENING (DIAMETER)		31-3/8"	<b>79.69 cm</b>
DOOR SILL HEIGHT		26-1/4"	<b>66.68 cm</b>
WATER CONNECTION		N / A	
DRYERS PER 20'40' CONTAINER		3 / 7	
DRYERS PER 48'53' TRUCK		9 / 9	
<b>Gas</b>	VOLTAGE AVAILABLE		
	APPROXIMATE NET WEIGHT		
	APPROXIMATE SHIPPING WEIGHT		
	AIRFLOW		
	HEAT INPUT		
	EXHAUST CONNECTION (DIAMETER)		
	COMPRESSED AIR CONNECTION		
	COMPRESSED AIR VOLUME		
	INLET PIPE CONNECTION		
	N / A		
<b>Electric</b>	VOLTAGE AVAILABLE		
	APPROXIMATE NET WEIGHT		<b>738.90 kg</b>
	APPROXIMATE SHIPPING WEIGHT		<b>795.60 kg</b>
	AIRFLOW		<b>60.88 cmm</b>
	EXHAUST CONNECTION (DIAMETER)		<b>40.64 cm</b>
	COMPRESSED AIR CONNECTION		
	COMPRESSED AIR VOLUME		
	OVEN SIZE		
	kW	Btu/hr	<b>kcal/hr</b>
	60	204,780	<b>51,608</b>
72	245,700	<b>61,900</b>	
VOLTAGE AVAILABLE		208-600v 3ø 3,4w 50/60 Hz	
APPROXIMATE NET WEIGHT		1,629 lb	
APPROXIMATE SHIPPING WEIGHT		1,754 lb	
AIRFLOW		2,150 cfm	
EXHAUST CONNECTION (DIAMETER)		16"	
COMPRESSED AIR CONNECTION		1/8" N.P.T.	
COMPRESSED AIR VOLUME		N / A	
<b>Steam</b>	VOLTAGE AVAILABLE		
	APPROXIMATE NET WEIGHT		<b>811.93 kg</b>
	APPROXIMATE SHIPPING WEIGHT		<b>868.63 kg</b>
	AIRFLOW		<b>55.22 cmm</b>
	STEAM CONSUMPTION		<b>204.12 kg/hr</b>
	OPERATING STEAM PRESSURE		<b>8.62 bar</b>
	EXHAUST CONNECTION (DIAMETER)		<b>40.64 cm</b>
	COMPRESSED AIR CONNECTION		
	COMPRESSED AIR VOLUME		<b>0.09 cmh</b>
	BOILER HORSEPOWER (NORMAL LOAD)		
	SUPPLY CONNECTION		
	RETURN CONNECTION		

Shaded areas are stated in metric equivalents

Engineer September 2004

# ADEH-120 HEPA FILTER DRYER

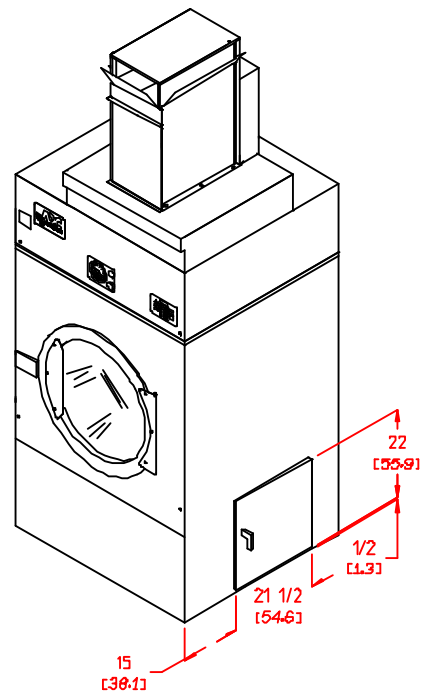
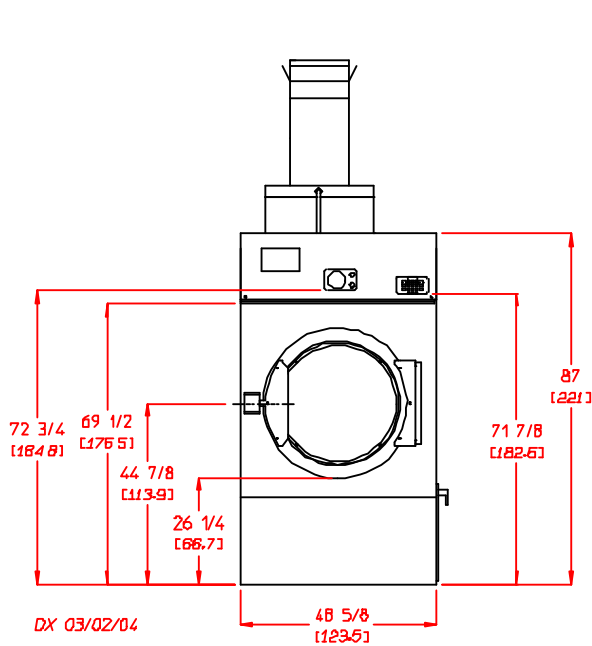
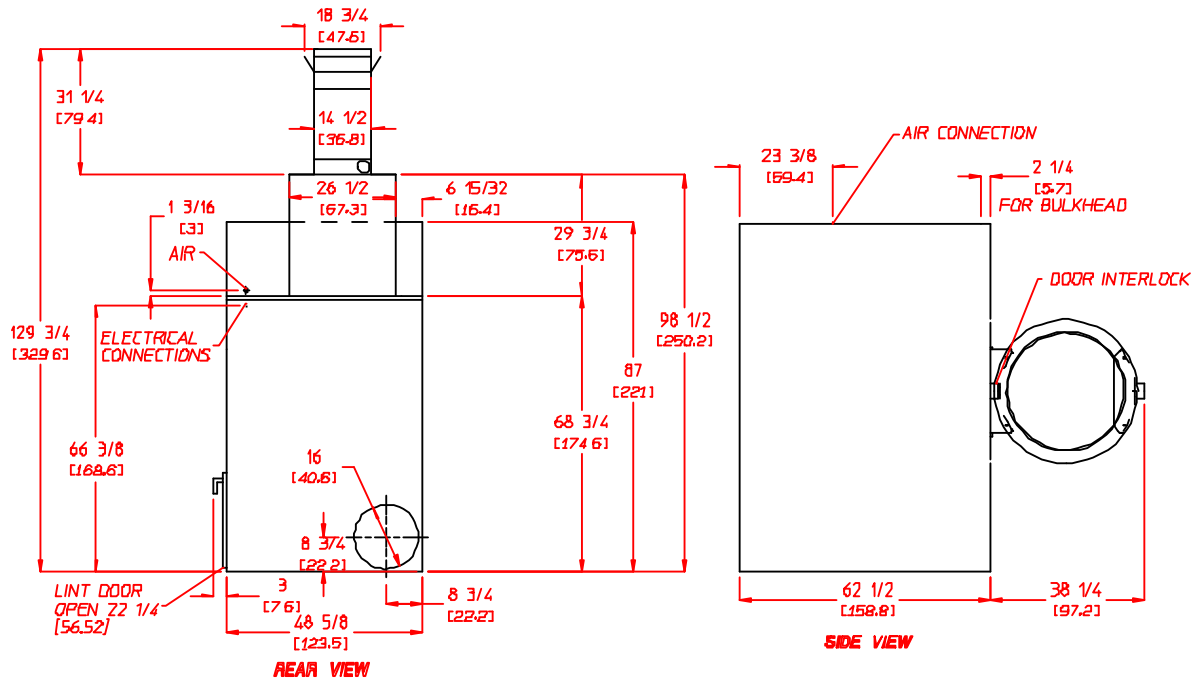

88 Currant Road • Fall River, MA 02720  
 Tel. 508-678-9000 • Fax 508-678-9447  
 sales@amdry.com • www.amdry.com